

OMMELIFT 3710

121' WORKING HEIGHT

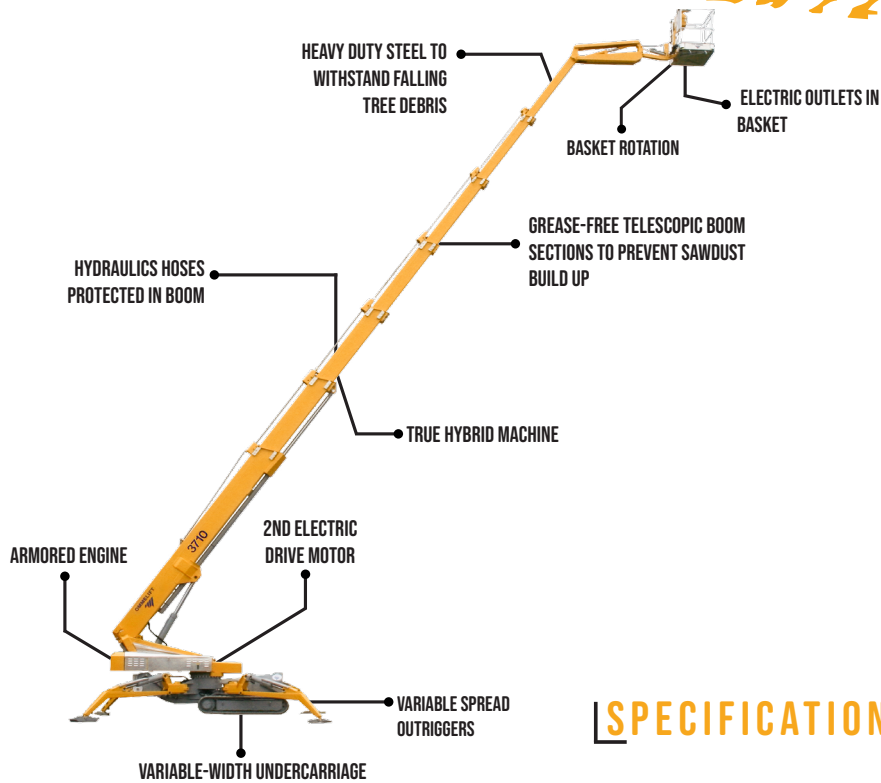

SPECIFICATIONS

Max. working height	121'4"
Max. outreach	44'9" (at 176 lbs)
Max. basket load	550 lbs
Basket size	2'8" x 2'6" x 3'7" (1-man basket interior)
Basket rotation	+ / - 41°
Turret rotation	+ / - 355°
Traveling length	26'7" / (24'6" without basket)
Traveling height	6'6"
Traveling width	3'8" (narrow mode) / 4'11" (wide mode)
Outrigger Spread	17'5" X 17'5" wide position / 21'10" x 10'6" narrow position
Battery	24V/400Ah/5h
Charger	24V / 25A
Diesel engine	14kW / 18.8HP
Total weight	12,566 lbs
Gradability, max. across slope	35% (19.3°)
Gradability, max. up and down slope	35% (19.3°)
Deployment ability on slopes up to	30% (16.7°)

DIAGRAMS

DATA AND DIMENSIONS ARE INDICATIVE AND NOT BINDING

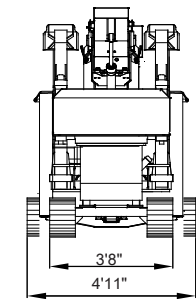
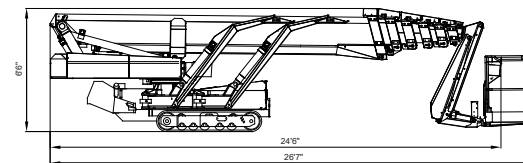
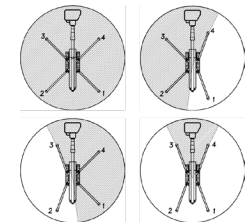
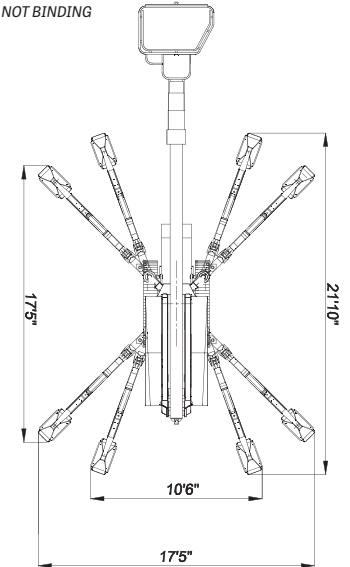
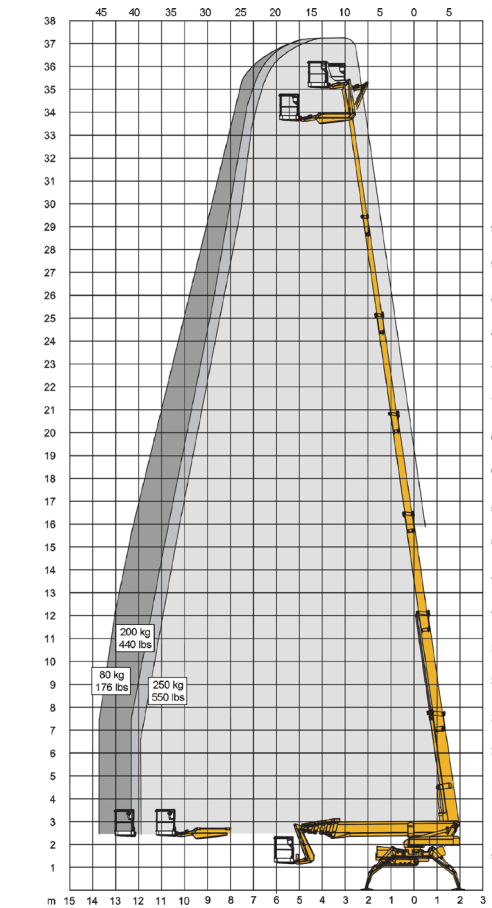

ADD-ON OPTIONS:

- White Rubber Non-Marking Tracks
- Custom Colors
- Spotlight in Basket
- Flashing Beacon Lights on Boom Stabilizers (5)
- Radio Remote Control Drive
- Auto Leveling
- Intercom
- Battery only (400Ah) version