

Articulated

72' Arborist 46kV Insulated

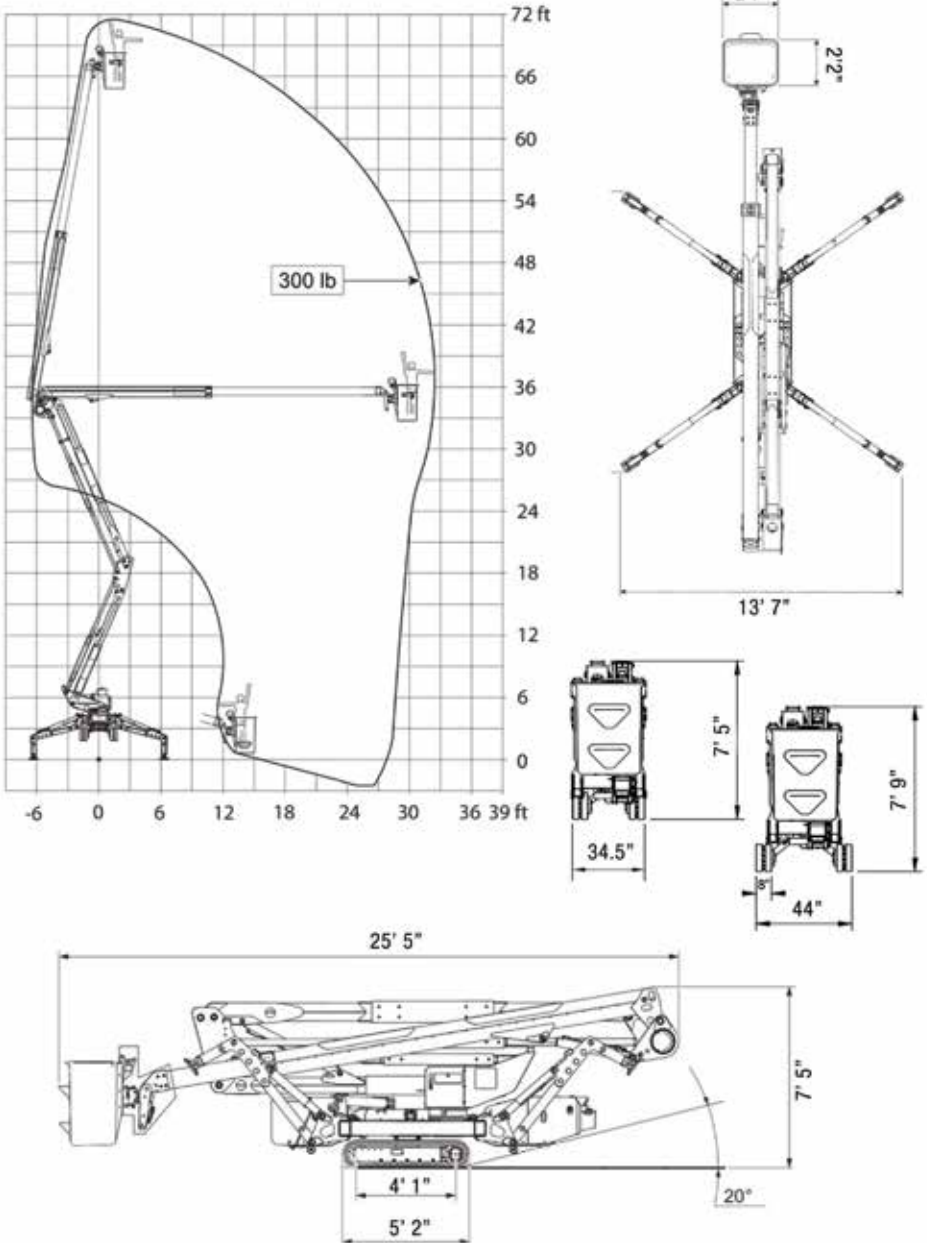

DATA DIMENSIONS AND FEATURES ARE INDICATIVE AND NOT BINDING.

www.TrackedLifts.com 1-866-543-8575

TECHNICAL DATA 72' Arborist 46kV

Max Working height, ft	72'
Height to Basket Floor	65'
Side Reach at 300 lbs	32.8'
Turret Rotation	±180°
Basket Rotation	±90°
Basket Dimensions	2'7" x 2'2" x 3'7"
Length (Transport)	25'5"
Width (Min/Max)	34.5"/44"
Height Stowed (Min/Max)	6'9"/7'5"
Outrigger Spread	13'7" x 14'
Driving Speed	.9 MPH
Gradeability (Uphill)	16°
Gradeability (Sideslope)	16°
Deployment Slope	16°
Max Capacity	400 lbs
Diesel Engine (Kubota)	15 HP
Total Weight of the Machine	7,937 lbs

STANDARD FEATURES

Category C 46kV insulation of all boom sections

Hydraulic tool circuit

Kubota Diesel

Electro-Mechanical Safety and Ground Pressure Monitoring System

Variable-Width Undercarriage

Stabilizers/Booms Interblock (Outriggers Disabled once Boom In Operation)

Lock Valves on all the Actuators

12V Electrical Emergency Descent System

1-man Basket

Emergency Hand Pump

Hour Meter

Heavy Duty Shield Package

Black Rubber Tracks

OPTIONS

White Rubber Non-Marking Tracks
Custom Colors