

# OMMELIFT 2650 46KV

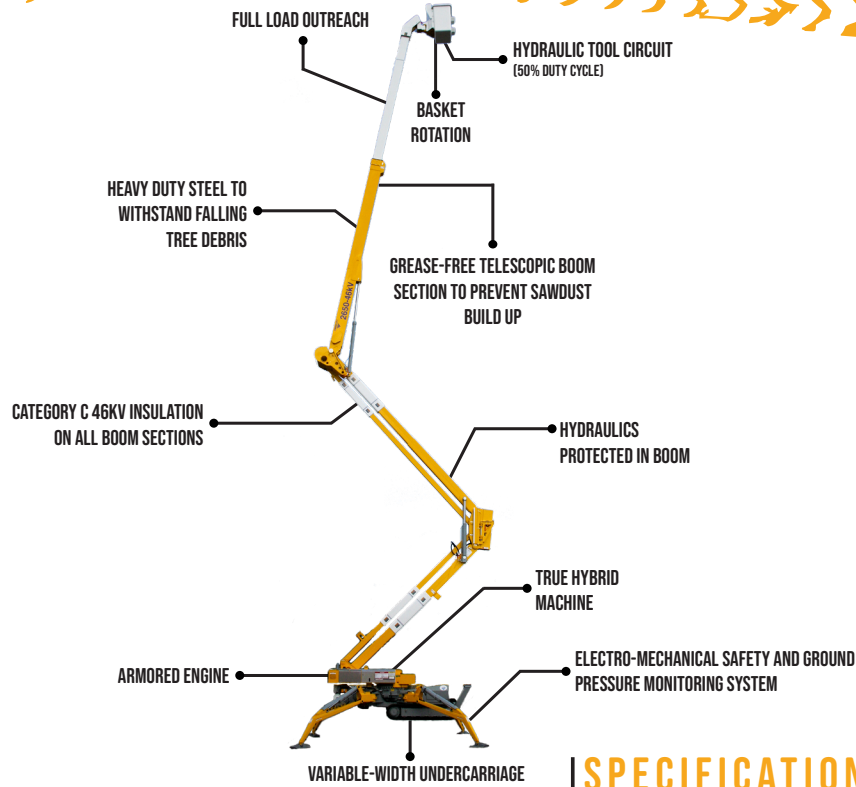

## SPECIFICATIONS

<b>Max. working height</b>	86'
<b>Max. outreach</b>	40'1" (at 300 lbs)
<b>Max. basket load</b>	300 lbs
<b>Basket size</b>	2'5" x 1'11" x 3'5" (1-man bucket interior)
<b>Basket rotation</b>	± 90°
<b>Turret rotation</b>	+ / - 355°
<b>Traveling length</b>	33'7"
<b>Traveling height</b>	7'11"
<b>Traveling width</b>	3'8" (narrow mode) / 4'11" (wide mode)
<b>Outrigger Spread</b>	17'5" x 17'5" wide position / 21'10" x 10'7" narrow position
<b>Battery</b>	24V / 200Ah / 5h
<b>Charger</b>	24V / 25A
<b>Diesel engine</b>	18.5kW/24.8hp
<b>Total weight</b>	13,400 lbs
<b>Gradability, max. across slope</b>	35% (19.3°)
<b>Gradability, max. up and down slope</b>	35% (19.3°) - approach angle 21% (12.0°)
<b>Deployment ability on slopes up to</b>	40% (21.8°)

## DIAGRAMS

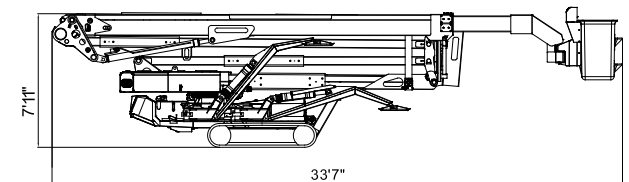
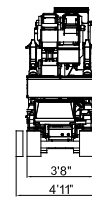
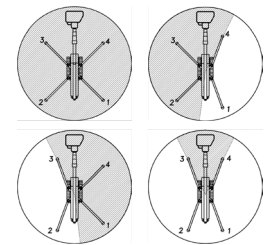
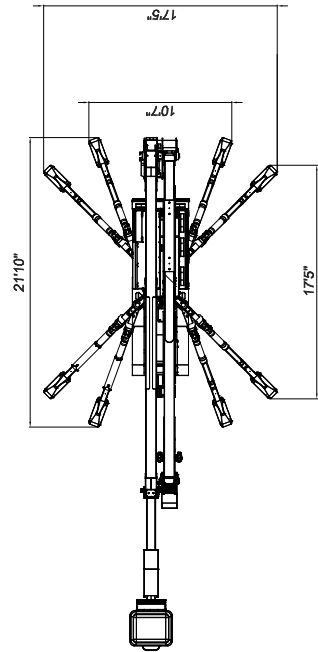
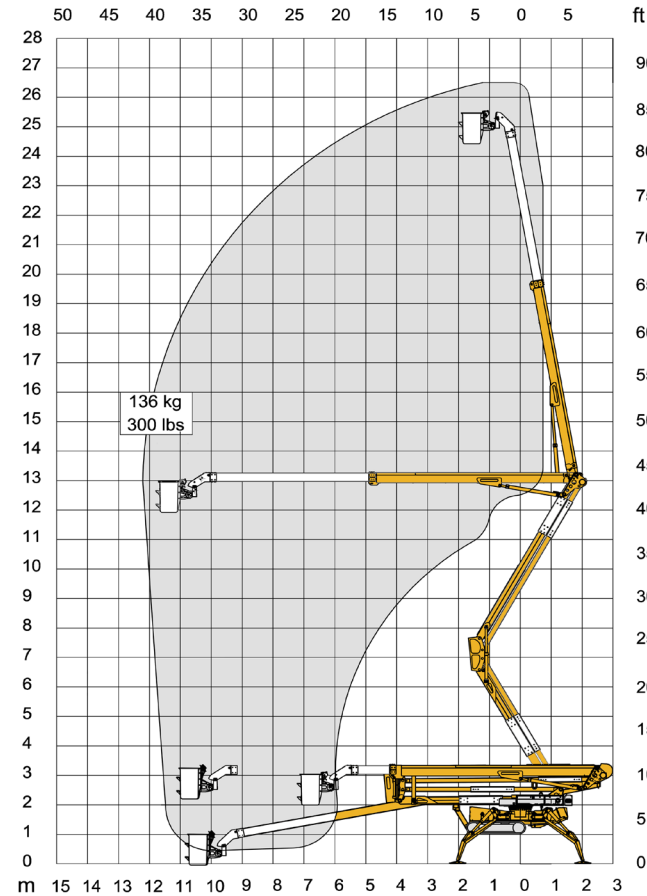

## ADD-ON OPTIONS:

- White Rubber Non-Marking Tracks
- Custom Colors
- 24V 400Ah Deep Cycle Battery Pack