

PLATFORM BASKET 18.90

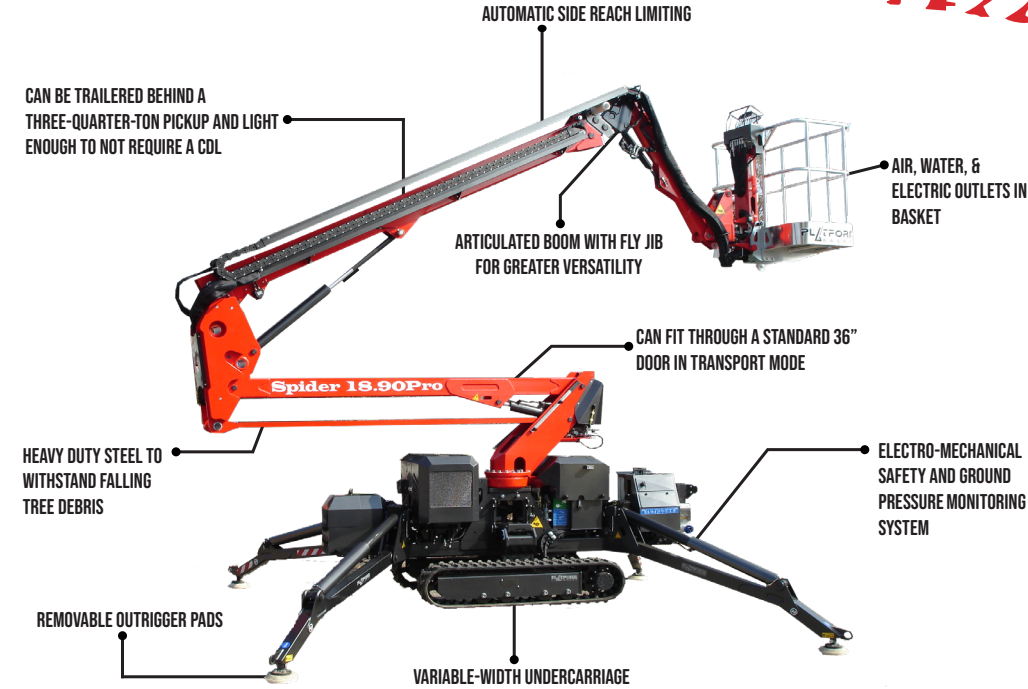

SPECIFICATIONS

Max. working height	60'
Max. outreach	30'10" (177 lbs) / 27'1" (265 lbs) / 22'9" (440 lbs)
Max. basket load	440 lbs
Basket size	2'3" x 1'11" x 3'7" (1-man basket interior)
Turret rotation	+ / - 180°
Traveling length	16'5" (14'3" without basket)
Traveling height	6'6" (narrow mode) / 7'2" (wide mode)
Traveling width	2'7" (narrow mode) / 3'6" (wide mode)
Outrigger Spread	12'1" x 10'2"
Battery	110V Emergency Descent System
Engine	Honda Gasoline, 13 HP
Total weight	5,290 lbs
Gradability, max. across slope	31% (17°)
Gradability, max. up and down slope	29% (16°)
Deployment ability on slopes up to	31% (17°)

DIAGRAMS

DATA AND DIMENSIONS ARE INDICATIVE AND NOT BINDING

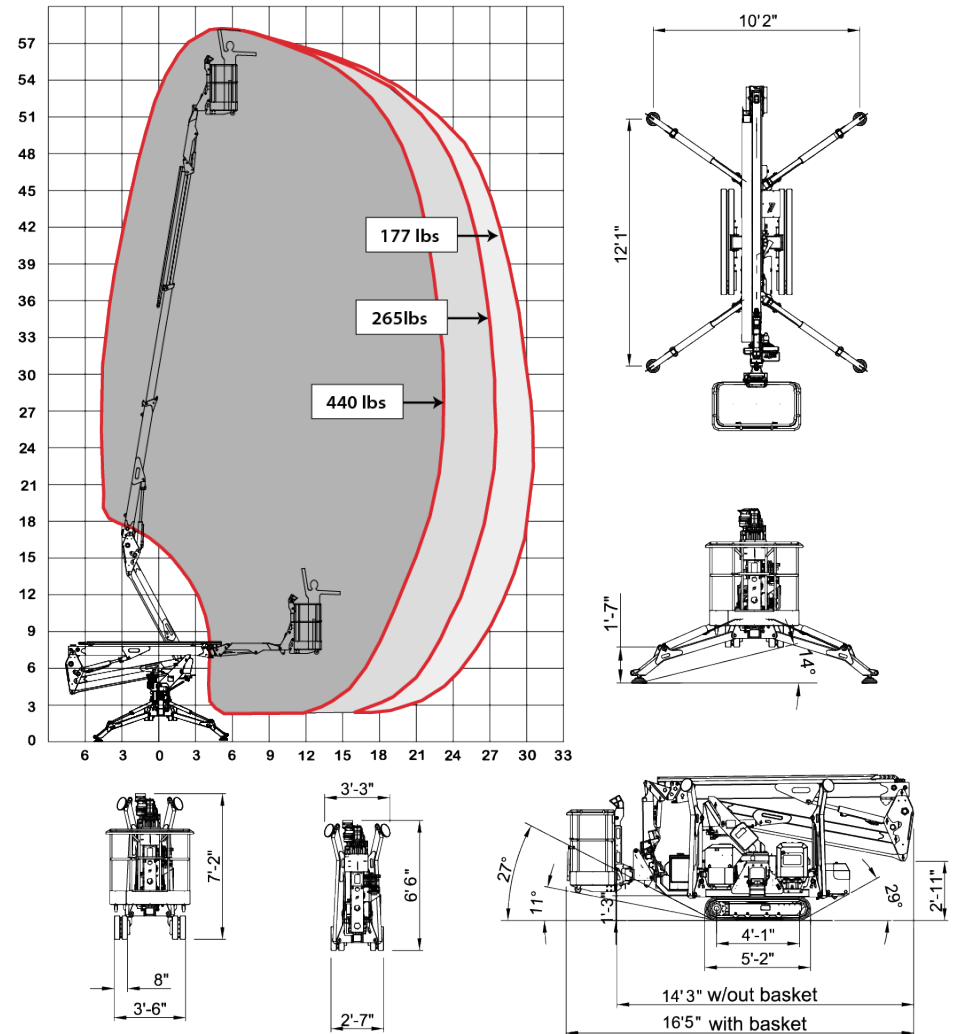

ADD-ON OPTIONS:

- White Rubber Non-Marking Tracks
- Custom Colors
- 2-man Basket
- Kubota Diesel
- Kubota Diesel + 24V Battery Hybrid
- Emergency 12V Hydraulic System
- Drive & Stabilization Radio Remote Control
- Lithium Ion Battery Pack
- 2 Speed Drive Motors
- Increased Size of Foot Plates (13.75" Diameter)
- Basket Rotation